

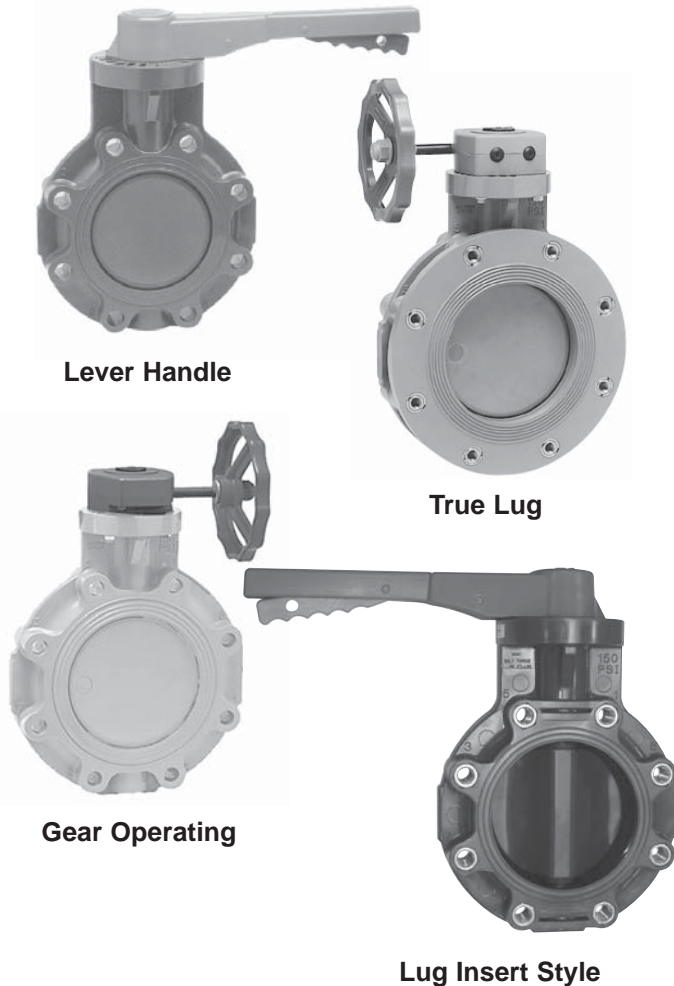

## BUTTERFLY VALVES

### Standard & True Lug Design



Lever Handle

True Lug

Gear Operating

Lug Insert Style

### Sample Engineering Specification

All thermoplastic valves shall be Butterfly type constructed from PVC Type I Cell Classification 12454 or CPVC Type IV Cell Classification 23447. All valve seats and O-rings shall be Buna-N, EPDM or Viton®. Seat shall be a non-liner type interlocked to valve body. Bolt hole patterns shall conform to ANSI/ASME B16.5 Class 150. Disc shall be offset design with fully isolated Type 316L stainless steel stem and Type 316 stainless steel hardware. Lever operated valves shall be equipped with high impact polypropylene handle having built-in lockout capability. Gear operated valves shall be equipped with position indicator and high impact polypropylene handwheel. Valve bodies shall accept field installable lug inserts or shall be factory installed lug inserts, or be True Lug type. Lugs shall be stainless steel or zinc plated steel. Valves shall be pressure rated at 150 psi for water at 73°F, as manufactured by Spears® Manufacturing Company.

### Features - PVC, CPVC

Spears® patented Butterfly Valve design departs from traditional liner-seat type valve to eliminate seat creep, reduce operating torque and provide positive seal-off. Ideally suited for flow control or throttling, this high-performance valve is offered with a full variety of options for greater application versatility in industrial and chemical processing applications. Available in IPS sizes 1-1/2" - 12" in Standard or True Lug (factory installed lugs) style.

- Special off-set Disc lifts quickly from seat to reduce wear and reduce operating torque.
- Patented Limited Contact Seat design provides free travel - eliminates seat creep, extrusion and wear. Field replaceable without full valve disassembly.
- Interlocking Body & Seat prevents wash-out or blow-out.
- Buna-N, EPDM or Viton® Seat & Seals
- Fully Isolated Solid Type 316L Stainless Steel Stem
- Reversible High Impact Polypropylene Lever Handle with 7-Position stops & Built-in Lockout (standard handle on 1-1/2" - 8" valves; not available on 10" & larger valves)
- High Efficiency Gear Operator with Cast Aluminum Housing, Polypropylene Handwheel, and Built-in Position Indicator (available for all sizes; standard on 10" & larger valves)
- Lug Insert Style valve has factory installed SS316 or zinc plated lug inserts.
- Standard valve accepts field-installable Lug Inserts Set option
- True Lug design has factory installed zinc plated or SS 316 lugs and is specially designed for connection to either side of valve.
- Pressure Rated to 150 psi @ 73°F including Dead-End Service.
- ANSI/ASME B16.5 Class 150 Bolt Pattern
- Valves with EPDM Seals & Seats NSF Certified for Potable water use.

### Optional Accessories

- Teflon® Coated Stem
- Stem Extension Kit
- PTFE Seat Sleeve
- Lever Handle Kit (standard on 1-1/2" - 8" valves)
- Gear Operator Kit (standard on 10" & larger valves)
- T-Handle Kit
- Field Installable Lug Insert Sets (for Standard valve)
- Speed Handle (for gear operated valves)
- 2" Square/T-Style Operator Nut (for gear operated valves)
- Chainwheel Operator Kit (for gear operated valves)
- Positive Stem Stop (for gear operated valves)
- Submersible Gear Operators

\* See "BUTTERFLY VALVE ACCESSORIES" section for details of individual products.

# BUTTERFLY VALVES



## Standard & Lug Insert Style Quick-View Valve Selection Chart

Valve Size	O-ring Material	STANDARD VALVE DESIGN			LUG INSERT VALVE DESIGN			Pressure Rating
		PVC Part Number <sup>1</sup>			PVC Part Number <sup>1</sup> Installed with 316 Stainless Steel Lug Inserts <sup>2</sup>			
		w/Lever Handle	w/Gear Operator	Valve Only	w/Lever Handle	w/Gear Operator	Valve Only	
1-1/2	Buna-N	721311-015	721321-015	721301-015	721311G-015	721321G-015	721301G-015	150 psi Non-Shock Water @ 73°F
	EPDM	722311-015	722321-015	722301-015	722311G-015	722321G-015	722301G-015	
	Viton®	723311-015	723321-015	723301-015	723311G-015	723321G-015	723301G-015	
2	Buna-N	721311-020	721321-020	721301-020	721311G-020	721321G-020	721301G-020	
	EPDM	722311-020	722321-020	722301-020	722311G-020	722321G-020	722301G-020	
	Viton®	723311-020	723321-020	723301-020	723311G-020	723321G-020	723301G-020	
2-1/2	Buna-N	721311-025	721321-025	721301-025	721311G-025	721321G-025	721301G-025	
	EPDM	722311-025	722321-025	722301-025	722311G-025	722321G-025	722301G-025	
	Viton®	723311-025	723321-025	723301-025	723311G-025	723321G-025	723301G-025	
3	Buna-N	721311-030	721321-030	721301-030	721311G-030	721321G-030	721301G-030	
	EPDM	722311-030	722321-030	722301-030	722311G-030	722321G-030	722301G-030	
	Viton®	723311-030	723321-030	723301-030	723311G-030	723321G-030	723301G-030	
4	Buna-N	721311-040	721321-040	721301-040	721311G-040	721321G-040	721301G-040	
	EPDM	722311-040	722321-040	722301-040	722311G-040	722321G-040	722301G-040	
	Viton®	723311-040	723321-040	723301-040	723311G-040	723321G-040	723301G-040	
6	Buna-N	721311-060	721321-060	721301-060	721311G-060	721321G-060	721301G-060	
	EPDM	722311-060	722321-060	722301-060	722311G-060	722321G-060	722301G-060	
	Viton®	723311-060	723321-060	723301-060	723311G-060	723321G-060	723301G-060	
8	Buna-N	721311-080	721321-080	721301-080	721311G-080	721321G-080	721301G-080	
	EPDM	722311-080	722321-080	722301-080	722311G-080	722321G-080	722301G-080	
	Viton®	723311-080	723321-080	723301-080	723311G-080	723321G-080	723301G-080	
10	Buna-N	10" AND LARGER NOT AVAILABLE WITH LEVER HANDLE	721321-100	721301-100	10" AND LARGER NOT AVAILABLE WITH LEVER HANDLE	721321G-100	721301G-100	
	EPDM		722321-100	722301-100		722321G-100	722301G-100	
	Viton®		723321-100	723301-100		723321G-100	723301G-100	
12	Buna-N		721321-120	721301-120		721321G-120	721301G-120	
	EPDM		722321-120	722301-120		722321G-120	722301G-120	
	Viton®		723321-120	723301-120		723321G-120	723301G-120	

1: For CPVC valves, add the letter "C" to part numbers listed (e.g., 722311-030C).

2: For factory installed Lug Insert Valve with Zinc Plated Lugs, substitute the letter "K" for the letter "G" (e.g. 721311K-030)

3: For True Lug Design Valve with Stainless Steel Lugs, substitute the letter "G" with the letter "L" (e.g. 21311L-030).

4: For True Lug Design Valve with Zinc Plated Steel Lugs, substitute the letter "Z" for the letter "G" (e.g. 721311Z-030).

**Note:** Optional BFV with submersible gear operators available, inquire with Spears®.

## Temperature Pressure Rating

System Operating Temperature °F (°C)		100 (38)	110 (43)	120 (49)	130 (54)	140 (60)	150 (66)	160 (71)	170 (77)	180 (82)	190 (88)	200 (93)	210 (99)
Valve Pressure Rating psi (MPa)	PVC	150 (1.03)	135 (.93)	110 (.76)	75 (.52)	50 (.34)	-0- (-0-)	-0- (-0-)	-0- (-0-)	-0- (-0-)	-0- (-0-)	-0- (-0-)	-0- (-0-)
	CPVC	150 (1.03)	140 (.97)	130 (.90)	120 (.83)	110 (.76)	100 (.70)	90 (.62)	80 (.55)	70 (.48)	60 (.41)	50 (.34)	-0- (-0-)



# BUTTERFLY VALVES

## Polypropylene



### Sample Engineering Specification

All thermoplastic valves shall be Butterfly type constructed from Polypropylene, ASTM D 4101. All valve seats and O-rings shall be Buna-N, EPDM or Viton®. Seat shall be a non-liner type interlocked to valve body. Bolt hole pattern shall conform to ANSI/ASME B16.5 Class 150. Disc shall be offset design with fully isolated, Type 316L stainless steel stem and Type 316 stainless steel hardware. Lever operated valves shall be equipped with high impact polypropylene handle having built-in lockout capability. Gear operated valves shall be equipped with position indicator and high impact polypropylene handwheel. Valves shall be pressure rated at [see table] for water at 73°F, as manufactured by Spears® Manufacturing Company.

**Material Note:** UV Stabilized Polypropylene with beige pigment sizes 1-1/2" - 12" are glass reinforced, sizes 14" - 24" are not.

## Features

Spears® patented Butterfly Valve design departs from traditional liner-seat type valve to eliminate seat creep, reduce operating torque and provide positive seal-off. Broad range of chemical resistance makes Polypropylene well suited for industrial and chemical processing applications. Designed for flow control or throttling, this high-performance valve is offered with a full variety of options for greater application versatility. Available in IPS sizes 1-1/2" - 24" with custom produced 30" to 60" valves available.

- UV Stabilized Polypropylene Construction
- Special off-set Disc lifts quickly from seat to reduce wear and reduce operating torque.
- Patented Limited Contact Seat design provides free travel - eliminates seat creep, extrusion and wear. Field replaceable without full valve disassembly.
- Interlocking Body & Seat prevents wash-out or blow-out.
- Buna-N, EPDM or Viton® Seat & Seals
- Solid Type 316L Stainless Steel Stem, fully isolated from process fluids
- Reversible High Impact Polypropylene Lever Handle with 7-Position stops & Built-in Lockout (standard handle on 1-1/2" - 8" valves; not available on 10" & larger valves)
- High Efficiency Gear Operator with Cast Aluminum Housing, Polypropylene Handwheel, and Built-in Position Indicator (available for all sizes; standard on 10" & larger valves)
- Pressure ratings include Dead-End Service (See Chart).
- ANSI/ASME B16.5 Class 150 Bolt Pattern

## Optional Accessories

- Teflon® Coated Stem
- Stem Extension Kit
- PTFE Seat Sleeve (through 12" size)
- Lever Handle Kit (standard on 1-1/2" - 8" valves)
- Gear Operator Kit (standard on 10" & larger valves)
- T-Handle Kit
- Speed Handle (for gear operated valves)
- 2" Square/T-Style Operator Nut (for gear operated valves)
- Chainwheel Operator Kit (for gear operated valves)
- Positive Stem Stop (for gear operated valves)
- Submersible Gear Operators

\* See "BUTTERFLY VALVE ACCESSORIES" section for details of individual products.

# BUTTERFLY VALVES



## Polypropylene Quick-View Valve Selection Chart

Valve Size	O-ring Material	w/Lever Handle	w/Gear Operator	Valve Only	Pressure Rating
1-1/2	Buna-N	721311-015P	<b>Special Order</b>	721301-015P	150 psi Non-Shock Water @ 73°F
	EPDM	722311-015P	<b>Special Order</b>	722301-015P	
	Viton®	723311-015P	<b>Special Order</b>	723301-015P	
2	Buna-N	721311-020P	721321-020P	721301-020P	
	EPDM	722311-020P	722321-020P	722301-020P	
	Viton®	723311-020P	723321-020P	723301-020P	
2-1/2	Buna-N	721311-025P	721321-025P	721301-025P	
	EPDM	722311-025P	722321-025P	722301-025P	
	Viton®	723311-025P	723321-025P	723301-025P	
3	Buna-N	721311-030P	721321-030P	721301-030P	
	EPDM	722311-030P	722321-030P	722301-030P	
	Viton®	723311-030P	723321-030P	723301-030P	
4	Buna-N	721311-040P	721321-040P	721301-040P	
	EPDM	722311-040P	722321-040P	722301-040P	
	Viton®	723311-040P	723321-040P	723301-040P	
6	Buna-N	721311-060P	721321-060P	721301-060P	
	EPDM	722311-060P	722321-060P	722301-060P	
	Viton®	723311-060P	723321-060P	723301-060P	
8	Buna-N	721311-080P	721321-080P	721301-080P	
	EPDM	722311-080P	722321-080P	722301-080P	
	Viton®	723311-080P	723321-080P	723301-080P	
10	Buna-N	10" and Larger not available with Lever Handle	721321-100P	721301-100P	
	EPDM		722321-100P	722301-100P	
	Viton®		723321-100P	723301-100P	
12	Buna-N		721321-120P	721301-120P	
	EPDM		722321-120P	722301-120P	
	Viton®		723321-120P	723301-120P	
14	Buna-N		—	—	
	EPDM		722321-140P	722301-140P	
	Viton®		723321-140P	723301-140P	
16	Buna-N		—	—	
	EPDM		722321-160P	722301-160P	
	Viton®		723321-160P	723301-160P	
18	Buna-N		—	—	
	EPDM		722321-180P	722301-180P	
	Viton®		723321-180P	723301-180P	
20	Buna-N		—	—	
	EPDM		722321-200P	722301-200P	
	Viton®		723321-200P	723301-200P	
24	Buna-N		—	—	
	EPDM		722321-240P	722301-240P	
	Viton®		723321-240P	723301-240P	

Note: 30" - 60" Polypropylene Butterfly Valves produced to order

## Temperature Pressure Rating

System Operating Temperature °F (°C)		100 (38)	110 (43)	120 (49)	130 (54)	140 (60)	150 (66)	160 (71)	170 (77)	180 (82)	190 (88)
Valve Pressure Rating psi (MPa)	1-1/2"-12"	150 (1.03)	105 (.72)	90 (.62)	80 (.55)	65 (.45)	50 (.34)	45 (.31)	30 (.21)	20 (.14)	-0-
	14"	100 (.69)	70 (.48)	60 (.41)	53 (.37)	43 (.26)	33 (.23)	30 (.21)	20 (.14)	13 (.09)	-0-
	16"	85 (.59)	60 (.41)	51 (.35)	45 (.31)	37 (.26)	28 (.19)	26 (.18)	17 (.12)	11 (.08)	-0-
	18"	70 (.48)	49 (.34)	42 (.29)	37 (.26)	30 (.21)	23 (.16)	21 (.14)	14 (.10)	9 (.06)	-0-
	20"-24"	50 (34)	35 (.24)	30 (.21)	27 (.19)	22 (.15)	17 (.12)	15 (.10)	10 (.07)	7 (.05)	-0-



# BUTTERFLY VALVES

## High Purity TFM Lined

### Features - CPVC



This advanced technology TFM Lined valve is specially designed and produced for applications requiring high purity and maximum chemical resistance. Spears® exclusive component-interface seal fully isolates process media to disc and liner contact only. Custom produced in sizes 2" through 6".

- Direct disc-to-liner seal between ECTFE fluoropolymer disc and TFM liner for positive shut-off. Specially designed offset disc lifts quickly from sealing surface to minimize wear and reduce operating torque.
- Special disc-to-liner interface isolates valve components from process media. Eliminates stem and elastomer backing seal contact with process fluids. In the unlikely event of seal failure, leakage is expelled externally to protect process integrity. TFM skirt is integrally formed as part of the liner to isolate the CPVC body.
- Solid, fully isolated type 316 stainless steel stem is additionally PTFE coated as a safeguard.
- Lug style, chemical and corrosion resistant CPVC body features integrally molded actuation mounting pad and provides increased temperature handling capability to 200°F.
- 316 stainless steel Lug Inserts provide quick single-side valve installation and easy system add-on.
- Low Profile Gear Operator features high efficiency worm gear drive with built-in position indicator and high impact polypropylene handwheel. Operator housing is powder coated for improved cleanliness. Reversible for either right or left side operation.
- 150 psi Maximum Internal Pressure rating at 73°F.

### Sample Engineering Specification

All thermoplastic Butterfly Valves shall be constructed from CPVC Type IV Cell Classification 23447 with TFM liner and ECTFE disc. Disc and liner interface shall isolate valve components and elastomeric seals from process media. Valve Stem shall be PTFE coated type 316 stainless steel. Body shall be lug style with 18-8 stainless steel or type 316 stainless steel lugs. Bolt hole patterns shall conform to ANSI/ASME B16.5 Class 150. Valve shall be gear operated with powder coated operator housing, position indicator, and high impact polypropylene handwheel. Valve shall be pressure rated at 150 psi for water at 73°F, as manufactured by Spears® Manufacturing Company.

### Factory Reconditioning

In the event of damage, this maintenance-free valve can be factory reconditioned in order to maintain optimum serviceability and assure proper component isolation function. Valve reconditioning is made on an exchange basis with original limited warranty. Contact Spears® Technical Services for additional information.

### Material Specifications

#### Media Contact Components:

- Liner/seat** TFM (Hostafion® — modified - PTFE)
- Disc** ECTFE (HALAR® — ethylene chlorotrifluoroethylene)

#### No Media-Contact Components:

- Body** CPVC (chlorinated polyvinylchloride)
- Stem** Type 316 Stainless Steel, Teflon® (PTFE) coated
- O-ring Backing** Viton® (fluorocarbon)
- Bushings** Glass Reinforced Polypropylene blend / Polyurethane
- Gear Operator** Die Cast Aluminum
- Handwheel** Polypropylene

### Quick-View Valve Selection Chart

Valve Size	Part Number	Pressure Rating
2	253322-020	150 psi Non-Shock Water @ 73°F
3	253322-030	
4	253322-040	
6	253322-060	

NOTE: High Purity TFM Lined Butterfly Valve has the same basic dimensions as Spears® Standard Butterfly Valve.

HALAR® is a registered trademark of Ausimont, Inc.  
Hostafion® is a registered trademark of Hoechst Celanese Corporation.



# BUTTERFLY VALVES



## PVC Pool Butterfly Valves



### Sample Engineering Specification

All Pool Butterfly Valves shall be constructed from PVC with EPDM seals suitable for chlorinated water applications. Valve body shall be white (gray disc) with blue handle for application identification. All handles shall be high impact polypropylene. Lever handles shall have built-in lockout capability. Stem shall be Type 316L stainless steel and non-wetted. Valve bodies shall have ANSI/ASME B16.5 bolt patterns and accept optional field installable lug inserts. Valves shall be pressure rated at 150 psi for water at 73°F, as manufactured by Spears® Manufacturing Company.

### Quick-View Valve Selection Chart

PVC Lever Handle with EPDM Seat		
Size	Part Number	Pressure Rating
1-1/2	682311-015	150 psi Non-Shock Water @ 73°F
2	682311-020	
2-1/2	682311-025	
3	682311-030	
4	682311-040	
6	682311-060	
8	682311-080	
PVC Gear Operated with EPDM Seat		
Size	Part Number	Pressure Rating
1-1/2	682321-015	150 psi Non-Shock Water @ 73°F
2	682321-020	
2-1/2	682321-025	
3	682321-030	
4	682321-040	
6	682321-060	
8	682321-080	
10	682321-100	
12	682321-120	

### Features - PVC

Distinct White Body with Blue Handle readily identifies this high quality PVC Butterfly Valve specifically designed for chlorinated water applications such as swimming pools. Fully isolated, non-wetted stainless steel stem with limited-contact EPDM seat provides maximum resistance to chlorinated water with superior ease of operation. Available in IPS sizes 1-1/2" through 12".

- White PVC Valve with Blue PP Handle provides easy application identification for chlorinated water
- Type 316L non-wetted stainless steel stem is fully isolated from system fluid, but still compatible with chlorinated water
- Patented limited-contact seat is field replaceable
- High-grade EPDM seat & seals
- Blue polypropylene lever handle with built-in lockout (10" & 12" valves are gear operated only)
- Optional gear operated valve with powder coated cast aluminum housing and Blue polypropylene handwheel
- ANSI/ASME B16.5 Class 150 bolt pattern flange connection
- All sizes pressure rated to 150 psi @ 73°F
- Optional SS 316 field-installable Lug Inserts sets
- Pneumatic or electric actuation available

**CAUTION: THE POOL BUTTERFLY VALVE IS NEITHER INTENDED NOR WARRANTED FOR INDUSTRIAL OR CHEMICAL PROCESSING APPLICATIONS**

See dimensions and additional Technical Information on following pages



# BUTTERFLY VALVES

## Replacement Parts for 1-1/2" - 12" PVC & CPVC Standard, True Lug and Polypropylene Valves

No	Component	Qty.	Material
1	Body	1	PVC/CPVC
2	Stem Bearing	1	Teflon® GFPP
3	Seal Carrier	1	PVC/CPVC/PP
4	Seat	1	Buna-N, EPDM, Viton®
5	Disc	1	PVC/CPVC/PP
6	Stem Bushing	1	Teflon® GFPP
7	Bushing O-ring	2	Buna-N, EPDM, Viton®
8	Stem O-ring	2	Buna-N, EPDM, Viton®
9	Stem Washer - Hex	1	Teflon®
10	Stem Washer - Slot*	1-2	SS 316
11	Stem Washer - Round	1	Teflon® GFPP
12	Stem Nut	1	PVC/CPVC
13	Handle Grip	1	GFPVC
14	Handle Body	1	PP
15	Grip Pin	1	PP
16	Lock Pin	1	PP
17	Handle Lock	1	GFPVC
18	Handle Spring	1	SS 316
19	Handle Cover	1	PP
20	Hex Head Cap Screw	1	SS 316
21	Flat Washer	1	SS 316
22	Handle Bushing	1	GFPVC
23	Timing Stop	1	CPVC
24	Stem	1	SS 316
25	Lug Insert	4-12	SS/Zinc Plated Steel
26	Gear Operator Assembly	1	Cast Aluminum
27	Hand Wheel	1	PP
<b>True Lug Only (not shown):</b>			
	Seal Carrier Flange Plate	1	PVC/CPVC
	Lug & Nut	4-12	SS/Zinc Plated Steel
	Plate O-ring	1	Buna-N, EPDM, Viton®

Notes: 1: 2-Slotted washers used on 6" & larger  
2: See 14"-24" PP valve illustration for Gear Operator Components, No. 8 - 16

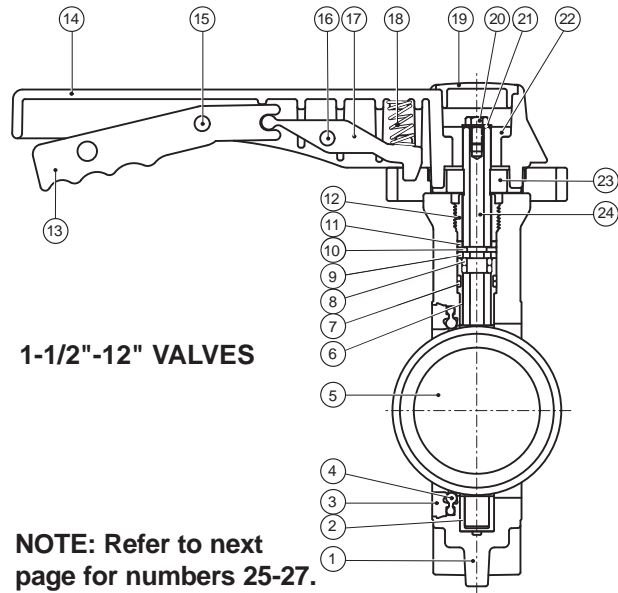

1-1/2"-12" VALVES

NOTE: Refer to next page for numbers 25-27.

## Replacement Parts for 14" - 24" Polypropylene Valves

No.	Component	Qty	Material
1	Body	1	PP
2	Seal Carrier	1	PP
3	Seat	1	EPDM/Viton®
4	Stem	1	SS 316L
5	Disc	1	PP
6	Stem O-ring	2	EPDM/Viton®
7	Set Screw	1	Steel
8	Drive Bushing	1	Steel
9	Gear Operator	1	Epoxy Coated Aluminum
10	Flat Washer	4	SS 316
11	Lock Washer	4	SS 316
12	Hex Head Cap Screw	4	SS 316
13	Handwheel Pin	1	SS 316
14	Handwheel Adapter	1	GFPVC
15	Handwheel Nut	1	PP
16	Handwheel	1	PP
17	Hex Bolts	6-12	Nylon
18	Thread Insert	2	Steel
19	Hex Head Cap Screws	2	SS 316
20	Dowel Pin	1	Steel
21	Tower	1	PP

## 14" - 24" VALVES

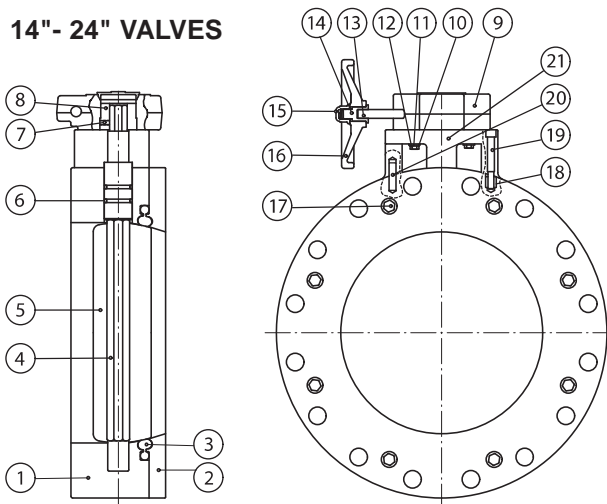

# BUTTERFLY VALVES



## Standard, True Lug & Polypropylene

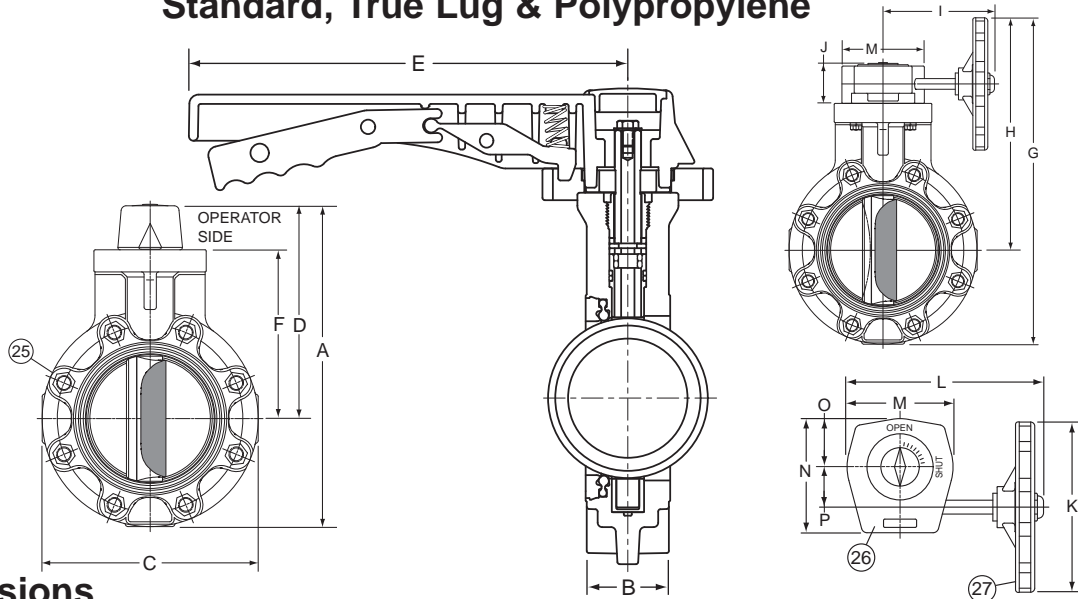

### Dimensions

Nominal Size	Pressure Rating <sup>1</sup> (psi)	A	B		C	D	E	F	G
			Standard, Lug Insert, & Polypropylene	True Lug					
1-1/2	150	8-5/32	1-9/16	2-1/4	5	5-19/32	9-3/32	4-3/32	11-5/32
2	150	9-11/32	1-15/16	2-9/16	6	6-13/32	9	4-3/4	13-1/8
2-1/2	150	10-9/32	2	2-3/4	7	6-25/32	9-1/4	5-1/4	13-1/8
3	150	11-1/2	2-3/32	2-13/16	7-1/2	7-27/32	12	5-5/8	14-5/32
4	150	13	2-9/32	3	9	8-1/2	12	6-1/4	15-5/8
6	150	16-13/32	2-3/4	3-13/32	11-1/16	10-7/8	13-15/16	8-5/8	19-7/32
8	150	18-5/8	2-15/16	3-23/32	13-1/2	12	13-15/16	9-1/2	21-7/16
10	150	N/A	3-1/4	4	16	N/A	N/A	11	26-5/8
12	150	N/A	3-1/2	4-1/2	19	N/A	N/A	12	29-1/8
14	100 <sup>2</sup>	N/A	6-1/4	N/A	21	N/A	N/A	13-3/16	29
16	85 <sup>2</sup>	N/A	6-3/4	N/A	23-1/2	N/A	N/A	14-7/16	31-1/2
18	70 <sup>2</sup>	N/A	7-1/8	N/A	25	N/A	N/A	15-3/16	33
20	50 <sup>2</sup>	N/A	7-3/4	N/A	27-1/2	N/A	N/A	16-7/16	35-1/2
24	50 <sup>2</sup>	N/A	8-7/16	N/A	32	N/A	N/A	18-11/16	40
30-60	Contact Spears® for 30" to 60" Valve Dimensions								

Nominal Size	H	I	J	K	L	M	N	O	P
1-1/2	8-21/32	6-7/16	2-3/8	8	8-13/16	4-13/16	5-3/16	2-13/16	1-27/32
2	10-1/8	6-7/16	2-3/8	8	8-13/16	4-13/16	5-3/16	2-13/16	1-27/32
2-1/2	9-5/8	6-7/16	2-3/8	8	8-13/16	4-13/16	5-3/16	2-13/16	1-27/32
3	10-17/32	6-7/16	2-3/8	8	8-13/16	4-13/16	5-3/16	2-13/16	1-27/32
4	11-1/8	6-7/16	2-3/8	8	8-13/16	4-13/16	5-3/16	2-13/16	1-27/32
6	13-23/32	6-7/16	2-13/32	7-15/16	8-7/8	4-27/32	5-5/32	2-7/32	1-27/32
8	14-11/16	6-7/16	2-13/32	7-15/16	8-7/8	4-27/32	5-3/16	2-7/32	1-27/32
10	18-5/8	7-1/8	2-3/8	8	9-13/16	5-3/8	5-15/16	2-7/16	2-11/32
12	19-5/8	7-1/8	2-3/8	8	9-13/16	5-3/8	5-15/16	2-7/16	2-11/32
14	18-1/2	7-3/8	2-9/16	8	10-13/16	6-7/8	7-7/16	3-1/8	3
16	19-3/4	7-3/8	2-9/16	8	10-13/16	6-7/8	7-7/16	3-1/8	3
18	20-1/2	7-3/8	2-9/16	8	10-13/16	6-7/8	7-7/16	3-1/8	3
20	21-3/4	7-3/8	2-9/16	8	10-13/16	6-7/8	7-7/16	3-1/8	3
24	24	7-3/8	2-9/16	8	10-13/16	6-7/8	7-7/16	3-1/8	3
30-60	Contact Spears® for 30" to 60" Valve Dimensions								

1: Maximum Internal Pressure Rating @ 73°F

2: Additional pressure rating is possible with attention to flow direction.





# BUTTERFLY VALVES

## C<sub>v</sub> Values & Operating Torque

Valve Size	C <sub>v</sub> <sup>1</sup> Degrees Open						Operating Torque <sup>2</sup> (in.-lbs.)
	15°	30°	45°	60°	75°	90°	
1-1/2	2	8	20	36	61	81	100
2	3	11	27	49	82	109	110
2-1/2	5	19	48	86	144	192	206
3	9	35	86	155	259	345	360
4	10	41	103	185	308	411	420
6	28	113	281	506	844	1125	720
8	56	225	562	1012	1687	2249	1200
10	111	444	1110	1998	3330	4440	1320
12	158	631	1577	2839	4732	6309	1920
14	176	705	1762	3172	5286	7048	See Notes
16	211	846	2114	3805	6341	8455	
18	273	1092	2730	4914	8190	10920	
20	355	1418	3545	6381	10635	14180	
24	467	1866	4665	8397	13995	18660	

- 1: Gallons per minute at 1 psi pressure drop.  
 2: Operating torque for large diameter valves varies significantly with system operating pressure, flow direction and velocity. Contact Spears® for torque requirement based on application.

## Actuator Mounting Dimensions For Custom Actuation

Size	Bolt Hole Spacing		Bolt Hole Diameter		Bolt Circle Diameter		Hex	Square	Stem Height	
							+ .000 - .006	+ .000 - .002		
	Standard	Wafer	Standard	Wafer	Standard	Wafer	Standard	Wafer	Standard	Wafer
1-1/2	1.95	N/A	.34	N/A	2.75	N/A	.375	N/A	.75	N/A
2	1.95	2.47	.34	.40	2.75	3.50	.500	.375	.75	1.30
2-1/2	1.95	2.47	.34	.40	2.75	3.50	.500	.375	.75	1.34
3	2.65	2.47	.41	.40	3.75	3.50	.563	.500	1.00	1.34
4	2.65	2.47	.41	.40	3.75	3.50	.625	.500	1.04	1.37
6	3.17	2.83	.41	.40	4.48	4.00	.875	.750	1.27	1.80
8	3.17	3.17	.41	.40	4.48	4.48	1.000	.875	1.29	1.96
10	3.54	N/A	.41	N/A	5.00	N/A	1.125	N/A	1.38	N/A
12	3.54	N/A	.41	N/A	5.00	N/A	1.250	N/A	1.38	N/A
14	3.54	N/A	.41	N/A	5.00	N/A	1.250	N/A	1.62	N/A
16	3.54	N/A	.41	N/A	5.00	N/A	1.250	N/A	1.75	N/A
18	3.54	N/A	.41	N/A	5.00	N/A	1.250	N/A	1.75	N/A
20	3.93	N/A	.41	N/A	5.56	N/A	1.250	N/A	1.75	N/A
24	4.33	N/A	.41	N/A	6.12	N/A	1.250	N/A	1.75	N/A

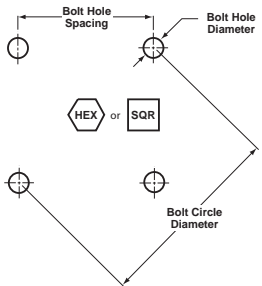
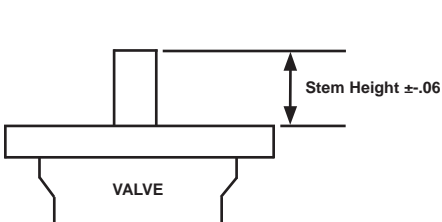

Note: Standard = Standard, Lug & True Lug Style Valves  
 Wafer = Wafer Style Valves

# BUTTERFLY VALVES



## General Installation Information

Spears® Butterfly Valves are designed for system connections either between two flanges, or with single-side (flange one-side only) connection for dead-end service using lug style valves. Lug Insert Valves require attention to flow direction, True Lug valves may be installed either direction. The valve handle (or gear operator) is reversible 180° for either left or right side operation. Spears® Butterfly Valves are designed for installation with user supplied 1/8" full-faced gaskets, hex bolts, nuts and flat washers.

**Caution:** Spears® Butterfly Valves are designed for use with flanges or flanged equipment having minimum waterway inside diameter no less than that of Schedule 80 PVC pipe (ASTM D 1785). *Use of smaller inside diameter flange connections may result in obstruction and damage to the valve disc.*

## PVC & CPVC Butterfly Valve Torque and Hardware Requirements

Valve Size (in.)	No. of Bolt Holes	Bolt Torque (ft.-lb.)	Standard Valve					Valve with Lug Inserts					True Lug Valve			
			Bolt Lengths <sup>1</sup> (in.)		Bolt Diameter (in.)	Bolt Threads per inch	Flat Washer O.D. (in.)	Bolt Lengths <sup>1</sup> (in.)		Bolt Diameter (in.)	Lug Threads per inch	Flat Washer O.D. (in.)	Bolt Lengths <sup>2</sup> (in.)	Bolt Diameter (in.)	Lug Threads per inch	Flat Washer O.D. (in.)
			Single Side	Dual Flange <sup>3</sup>				Single Side	2nd Flange <sup>2</sup>							
1-1/2	4	12	3-1/4	4-1/4	1/2	13	1-3/8	1-3/4	1-1/2	1/2	13	1-3/8	1-1/2	7/16	14	1-1/4
2	4	25	3-3/4	4-3/4	5/8	11	1-3/4	2	1-3/4	5/8	11	1-3/4	1-1/2	1/2	13	1-3/8
2-1/2	4	25	4-1/4	5-1/4	5/8	11	1-3/4	2-1/4	2	5/8	11	1-3/4	1-3/4	1/2	13	1-3/8
3	4	25	4-1/4	5-1/2	5/8	11	1-3/4	2-1/4	2	5/8	11	1-3/4	2	1/2	13	1-3/8
4	8	25	4-1/2	5-3/4	5/8	11	1-3/4	2-1/2	2	5/8	11	1-3/4	2	1/2	13	1-3/8
6	8	40	5-1/4	6-3/4	3/4	10	2	3-1/4	2-1/4	3/4	10	2	2-1/4	5/8	11	1-3/4
8	8	40	5-3/4	7-1/4	3/4	10	2	3-3/4	2-1/4	3/4	10	2	2-1/4	5/8	11	1-3/4
10	12	64	6-1/2	8-1/4	7/8	9	2-1/4	4	3	7/8	9	2-1/4	2-3/4	3/4	10	2
12	12	95	6-3/4	8-1/2	7/8	9	2-1/4	4-1/4	3	7/8	9	2-1/4	2-3/4	3/4	10	2

- 1: Minimum bolt lengths based on use of Spears® flanges, 1/8" full faced gaskets, standard S.A.E. hex bolts and Standard Plate "W" Series flat washers.
- 2: Specified bolt lengths are maximum allowable for maintaining proper clearance in initial Single-Side installation with Lugs where anticipated 2nd Flange installation option is to be retained without removal of valve.
- 3: Minimum bolt length through 2-flanges, 2-gaskets, 2-flat washers and 1-valve body.

## Single-Side (flange one side) Installation Using Standard Valve with Lug Inserts (for field installable Insert Sets or valves with factory installed Lug Inserts)

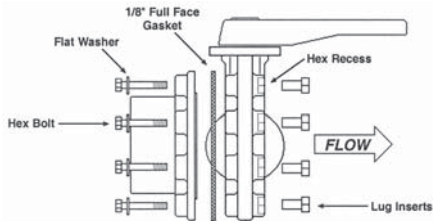

**CAUTION:** Flange must be installed on side of valve **opposite** the hex nut recesses for Single-Side Installation as illustrated.

(Flange, bolts, nuts, washers and gaskets not included. Lug inserts may be ordered separately.)

## Polypropylene Butterfly Valve Torque and Hardware Requirements

Valve Size	No. of Bolt Holes	Bolt Diameter (in.)	Bolt Torque (ft.-lb.)	Bolt Lengths	Valve Lay Length
1-1/2	4	1/2	12	Bolt lengths will vary according to thickness of valve, mating flanges, nuts and gaskets used.  The following formula may be use to calculate bolt length for installation with mating flange each side.  $L = V + 2 ( F + G + W ) + N$ Where: L = Minimum Bolt Length V = Valve Lay Length F = Flange Thickness G = Gasket Thickness W = Washer Thickness N = Nut Thickness	1-9/16
2	4	5/8	25		1-7/8
2-1/2	4	5/8	25		2-1/16
3	4	5/8	25		2-1/8
4	8	5/8	25		2-5/16
6	8	3/4	40		3
8	8	3/4	40		2-3/4
10	12	7/8	64		3-1/4
12	12	7/8	95		3-1/2
14	12	1	110		6-1/4
16	16	1	110		6-3/4
18	16	1-1/8	110		7-1/8
20	20	1-1/8	110		7-3/4
24	20	1-1/4	110		8-1/2



# BUTTERFLY VALVE ACCESSORIES

## Lug Insert Sets



- Field installable lugs for all Spears® PVC & CPVC Standard Butterfly Valves only.
- Allows easy single-side installation to mating flange.
- Choice of high corrosion resistant 316 stainless steel or zinc plated steel construction.

Valve Size	316 Stainless Steel Part Number	Zinc Plated Steel Part Number
1-1/2	LUG1-015	LUG2-015
2 & 2-1/2	LUG1-020	LUG2-020
3	LUG1-030	LUG2-030
4	LUG1-040	LUG2-040
6 & 8	LUG1-080	LUG2-080
10 & 12	LUG1-120	LUG2-120

## Lever Handle Kits



- Exact replacement or conversion handle for Spears® 1-1/2" through 8" Butterfly Valves.
- High impact polypropylene construction featuring quick-action reinforced polymer position stop and grip with built-in lock-out capability.
- Includes all components and hardware assembled for quick installation.

Valve Size	Part Number
1-1/2	BFH-015
2 & 2-1/2	BFH-020
3	BFH-030
4	BFH-040
6	BFH-060
8	BFH-080

## T-Handle Kits



- Specialty Handle for minimum space requirements.
- High impact polypropylene construction featuring quick-action reinforced polymer position stop and grip with built-in lock-out capability.

Valve Size	Part Number
3	BFTH-030
4	BFTH-040

## Speed Handle for Gear Operator



- Quickly attaches to Spears® Gear Operator Handle to allow rapid opening or closing of valve.

Valve Size	Part Number
1-1/2 - 12	SH-120

## Positive Stem Stop for Butterfly Valve with Gear Operator



- Provides positive stop for Gear Operator shaft to avoid changes in the degree of opening for varying flow conditions.

Valve Size	Part Number
1-1/2 - 12	PSS-120
14 - 24	PSS-240

# BUTTERFLY VALVE ACCESSORIES



## 2" Square / T-Style Operator Nuts

- Allows operation with conventional 2" Square or T-Style handle wrenches.
  - Fits All Spears® Butterfly Valve Gear Operators.
- (NOT FOR USE ON VALVE STEM)

Valve Size	Part Number
1-1/2 - 24	GTN-040

## Gear Operator Kits



For Wafer Style Butterfly Valves replace the "GO" prefix with "GOW" in the part number.

- Bolt-on conversion or replacement unit for all Spears® Butterfly Valves.
- Cast aluminum construction with high efficiency worm gear drive, built-in position indicator and easy-grip polypropylene handwheel.
- Includes all components and hardware for direct mount to valve.

## Gear Operator Kits

Valve Size	1-1/2	2	2-1/2	3	4	6	8	10	12
Part Number	GO-015	GO-020	GO-025	GO-030	GO-040	GO-060	GO-080	GO-100	GO-120

## Powder Coated Gear Operator Kits

Valve Size	1-1/2	2	2-1/2	3	4	6	8	10	12
Part Number	GOP-015	GOP-020	GOP-025	GOP-030	GOP-040	GOP-060	GOP-080	GOP-100	GOP-120

## Extended Chemical Resistance Options

Spears® offers several options for extended chemical resistance in PVC, CPVC and Polypropylene Butterfly Valves, including those listed below. Contact Spears® for additional ordering information.

### PTFE Seat Sleeves

- PTFE envelope-type sleeve encases and isolates Spears® standard elastomer seat for extended chemical resistance while maintaining resiliency and sealing capability.
- Available for valve sizes 1-1/2" - 12"
- Sold factory-installed in PVC, CPVC or PP valves.

### Teflon® Coated Valve Stems

- Durable, bonded Teflon® coating over standard SS 316L stem for extended chemical resistance.
- Viable alternative to more costly special alloy stems.
- Available for all valve sizes.
- Sold factory installed in PVC, CPVC or PP valves.



# BUTTERFLY VALVE ACCESSORIES



(VALVE NOT INCLUDED)

## Chainwheel Operator Kits

For Wafer Style Butterfly Valves replace the "CO" prefix with "COW" in the part number.

- Bolt-on conversion unit for all Spears® Butterfly Valves. Includes all hardware for direct mount to valve.
- Enables operation of Spears® Butterfly Valves in high, normally out of reach locations. Makes valve opening or closing easy by means of a slight pull on the sprocket chain.
- Unit consists of Cast Aluminum high efficiency Gear Operator with Aluminum Alloy Sprocket Rim and Chain Guide.
- Chain options provide choice of 316 Stainless Steel, Hot-Dipped Galvanized or Brass. Order separately to desired length.

**Note:** In horizontal system installations, Chainwheel Operators should be generally mounted with operator below valve (inverted valve) to maintain clearance between chain and system piping. Check for adequate clearance before installing an operator in a top-mount position.

Valve Size	Part Number
2	CO-020
2-1/2	CO-025
3	CO-030
4	CO-040
6	CO-060
8	CO-080
10	CO-100
12	CO-120
14	CO-140
16	CO-160
18	CO-180
20	CO-200
24	CO-240

2-1/2" and smaller kits available on special order basis.

LOCK-LINK CHAIN OPTIONS	Part Number
Hot-Dip Galvanized	GC-1
Brass	BC-1
Stainless Steel	SC-1

## Determining Floor-to-Chainwheel Height

Typical orientation is shown for valve in horizontal piping system installation. Floor-to-Chainwheel height is determined by subtracting the specified "C" dimension from the system centerline height (add "C" dimension if used with top-mount orientation). In vertical piping system installations, the Floor-to-Chainwheel height is the same as that for the centerline location of the valve in the system.

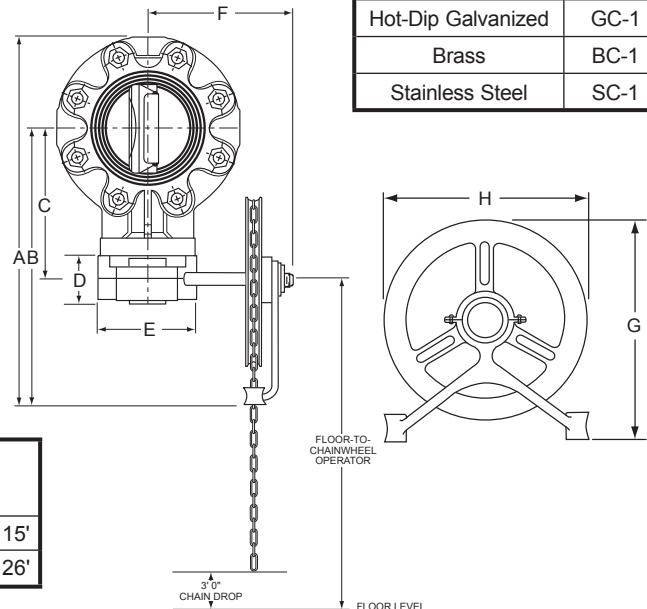

How to Order Chain									
Required chain length is based on chain drop at 3 ft. from floor.									
Floor-to-Chainwheel Height	7'	8'	9'	10'	11'	12'	13'	14'	15'
Required Chain Length	10'	12'	14'	16'	18'	20'	22'	24'	26'

## Chainwheel Operator Dimensions (Note: w denotes Wafer Style Butterfly Valve Dimensions)

Valve Size	A	A w	B	B w	C	C w	D	D w	E	E w	F	F w	G	G w	H	H w
2	12-15/16	12-3/16	9-15/16	9-1/8	5-7/8	5-1/8	2-3/8	2-3/8	4-13/16	4-13/16	5-7/16	5-7/16	7-3/4	7-3/4	7-3/8	7-3/8
2-1/2	13-11/16	13-3/16	10-3/16	9-5/8	6-1/8	5-5/8	2-3/8	2-3/8	4-13/16	4-13/16	5-7/16	5-7/16	7-3/4	7-3/4	7-3/8	7-3/8
3	14-7/16	13-3/4	10-11/16	10-1/16	6-5/8	6-1/16	2-3/8	2-3/8	4-13/16	4-13/16	5-7/16	5-7/16	7-3/4	7-3/4	7-3/8	7-3/8
4	15-15/16	14-13/16	11-7/16	10-1/2	7-3/8	6-1/2	2-3/8	2-3/8	4-13/16	4-13/16	5-7/16	5-7/16	7-3/4	7-3/4	7-3/8	7-3/8
6	19-5/16	17-13/16	13-13/16	12-1/4	9-3/4	8-1/4	2-3/8	2-3/8	4-13/16	4-13/16	5-7/16	5-7/16	7-3/4	7-3/4	7-3/8	7-3/8
8	21-9/16	20-7/16	14-13/16	13-9/16	10-3/4	9-9/16	2-3/8	2-3/8	4-13/16	4-13/16	5-7/16	5-7/16	7-3/4	7-3/4	7-3/8	7-3/8
10	24-3/16	-	16-3/16	-	12-1/8	-	2-3/8	-	5-3/8	-	6-7/16	-	7-3/4	-	7-3/8	-
12	26-11/16	-	17-3/16	-	13-1/8	-	2-3/8	-	5-3/8	-	6-7/16	-	7-3/4	-	7-3/8	-
14	31	-	20-1/2	-	14-1/2	-	2-3/4	-	6-7/8	-	7-1/4	-	10-1/2	-	9	-
16	33-1/2	-	21-3/4	-	15-3/4	-	2-3/4	-	6-7/8	-	7-1/4	-	10-1/2	-	9	-
18	35	-	22-1/2	-	16-1/2	-	2-3/4	-	6-7/8	-	7-1/4	-	10-1/2	-	9	-
20	37-1/2	-	23-3/4	-	17-3/4	-	2-3/4	-	6-7/8	-	7-1/4	-	10-1/2	-	9	-
24	42	-	26	-	20	-	2-3/4	-	6-7/8	-	7-1/4	-	10-1/2	-	9	-



# BUTTERFLY VALVE ACCESSORIES

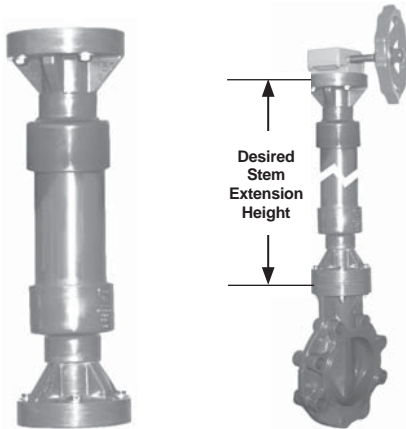

## Stem Extensions

For Wafer Style Butterfly Valves replace the "BFSE" prefix with "BFSEW" in the part number.

- Designed for use on Spears® Butterfly Valves.
- Corrosion Resistant PVC Housing.
- Stainless Steel Internal Extension Shaft.
- All Mounting Hardware Included.
- Detailed Instructions for Quick Assembly.
- Fabricated to Order in Standard 6" Increments.

*Typical Application (VALVE NOT INCLUDED)*

*Gear Operator (shown) or Lever Handle Sold with Valve*

Stem Extension Height	Valve Size						
	1-1/2	2 & 2-1/2	3	4	6	8	10
24	BFSE-015-240	BFSE-020-240	BFSE-030-240	BFSE-040-240	BFSE-060-240	BFSE-080-240	BFSE-100-240
30	BFSE-015-300	BFSE-020-300	BFSE-030-300	BFSE-040-300	BFSE-060-300	BFSE-080-300	BFSE-100-300
36	BFSE-015-360	BFSE-020-360	BFSE-030-360	BFSE-040-360	BFSE-060-360	BFSE-080-360	BFSE-100-360
42	BFSE-015-420	BFSE-020-420	BFSE-030-420	BFSE-040-420	BFSE-060-420	BFSE-080-420	BFSE-100-420
48	BFSE-015-480	BFSE-020-480	BFSE-030-480	BFSE-040-480	BFSE-060-480	BFSE-080-480	BFSE-100-480
54	BFSE-015-540	BFSE-020-540	BFSE-030-540	BFSE-040-540	BFSE-060-540	BFSE-080-540	BFSE-100-540
60	BFSE-015-600	BFSE-020-600	BFSE-030-600	BFSE-040-600	BFSE-060-600	BFSE-080-600	BFSE-100-600
66	BFSE-015-660	BFSE-020-660	BFSE-030-660	BFSE-040-660	BFSE-060-660	BFSE-080-660	BFSE-100-660
72	BFSE-015-720	BFSE-020-720	BFSE-030-720	BFSE-040-720	BFSE-060-720	BFSE-080-720	BFSE-100-720
78	BFSE-015-780	BFSE-020-780	BFSE-030-780	BFSE-040-780	BFSE-060-780	BFSE-080-780	BFSE-100-780
84	BFSE-015-840	BFSE-020-840	BFSE-030-840	BFSE-040-840	BFSE-060-840	BFSE-080-840	BFSE-100-840
90	BFSE-015-900	BFSE-020-900	BFSE-030-900	BFSE-040-900	BFSE-060-900	BFSE-080-900	BFSE-100-900
96	BFSE-015-960	BFSE-020-960	BFSE-030-960	BFSE-040-960	BFSE-060-960	BFSE-080-960	BFSE-100-960
102	BFSE-015-1020	BFSE-020-1020	BFSE-030-1020	BFSE-040-1020	BFSE-060-1020	BFSE-080-1020	BFSE-100-1020
108	BFSE-015-1060	BFSE-020-1080	BFSE-030-1080	BFSE-040-1080	BFSE-060-1080	BFSE-080-1080	BFSE-100-1080
114	BFSE-015-1140	BFSE-020-1140	BFSE-030-1140	BFSE-040-1140	BFSE-060-1140	BFSE-080-1140	BFSE-100-1140
120	BFSE-015-1200	BFSE-020-1200	BFSE-030-1200	BFSE-040-1200	BFSE-060-1200	BFSE-080-1200	BFSE-100-1200

Stem Extension Height	Valve Size					
	12	14	16	18	20	24
24	BFSE-120-240	BFSE-140-240	BFSE-160-240	BFSE-180-240	BFSE-200-240	BFSE-240-240
30	BFSE-120-300	BFSE-140-300	BFSE-160-300	BFSE-180-300	BFSE-200-300	BFSE-240-300
36	BFSE-120-360	BFSE-140-360	BFSE-160-360	BFSE-180-360	BFSE-200-360	BFSE-240-360
42	BFSE-120-420	BFSE-140-420	BFSE-160-420	BFSE-180-420	BFSE-200-420	BFSE-240-420
48	BFSE-120-480	BFSE-140-480	BFSE-160-480	BFSE-180-480	BFSE-200-480	BFSE-240-480
54	BFSE-120-540	BFSE-140-540	BFSE-160-540	BFSE-180-540	BFSE-200-540	BFSE-240-540
60	BFSE-120-600	BFSE-140-600	BFSE-160-600	BFSE-180-600	BFSE-200-600	BFSE-240-600
66	BFSE-120-660	BFSE-140-660	BFSE-160-660	BFSE-180-660	BFSE-200-660	BFSE-240-660
72	BFSE-120-720	BFSE-140-720	BFSE-160-720	BFSE-180-720	BFSE-200-720	BFSE-240-720
78	BFSE-120-780	BFSE-140-780	BFSE-160-780	BFSE-180-780	BFSE-200-780	BFSE-240-780
84	BFSE-120-840	BFSE-140-840	BFSE-160-840	BFSE-180-840	BFSE-200-840	BFSE-240-840
90	BFSE-120-900	BFSE-140-900	BFSE-160-900	BFSE-180-900	BFSE-200-900	BFSE-240-900
96	BFSE-120-960	BFSE-140-960	BFSE-160-960	BFSE-180-960	BFSE-200-960	BFSE-240-960
102	BFSE-120-1020	BFSE-140-1020	BFSE-160-1020	BFSE-180-1020	BFSE-200-1020	BFSE-240-1020
108	BFSE-120-1080	BFSE-140-1080	BFSE-160-1080	BFSE-180-1080	BFSE-200-1080	BFSE-240-1080
114	BFSE-120-1140	BFSE-140-1140	BFSE-160-1140	BFSE-180-1140	BFSE-200-1140	BFSE-240-1140
120	BFSE-120-1200	BFSE-140-1200	BFSE-160-1200	BFSE-180-1200	BFSE-200-1200	BFSE-240-1200

Basic Stem Extension height is 24" and is manufactured in standard 6" increments. Intermediate Stem Extension heights are available and are priced to the next full 6" increment. For heights over 120", please contact your servicing Spears® Regional Distribution Center.