

PVC, CPVC & PP SWING CHECK VALVES

SK-2-0801

Engineered for Demanding Industrial Applications



Designed for optimum flow, quick response and positive shut off with minimum turbulence, this rugged industrial grade Swing Check Valve is used in a wide variety of industrial and chemical processing applications where high volume fluid transfer is required. Suitable for horizontal or vertical applications. Available in flanged style IPS sizes 3/4" through 8".

Engineered for Full Flow Fluid Transfer

Unlike fixed in-line check devices, such as ball or spring loaded plungers, the Swing Check allows higher GPM fluid transfer with minimum restriction. Spears® computer engineered design provides contoured interior surfaces for optimum flow, minimum turbulence and less entrapment of any debris present in fluid media.

Quick Response, Low Closing Pressure Disc, Plus Optional Indicator Or Counterweight

Engineered to reduce "slamming", check disc responds quickly to back flow with as little as 0.5 psi closing pressure. Optional features include High Visibility Directional Arrow or exterior counter balance weight for fine tuning disc closing characteristics.

Heavy Bodied, All Plastic Interior Construction

Spears® design uses no metal components in contact with process fluids. Heavy bodied CPVC, PVC, or Polypropylene components provide superior strength and maximum chemical resistance.

Standard O-ring Seals in Choice of Elastomers

Spears® Swing Check Valves require no special seals or gaskets. Standard O-ring seals are used for seat, swing arm, bonnet, and drain plug available with EPDM or Viton® seals, plus special order PTFE encapsulated elastomer seals option.

Full Service Pressure Rating

Swing Check Valves are rated at 150 psi for sizes 3/4" - 4", 100 psi for 6", and 70 psi for 8" maximum internal pressure rating for water at 73°F.

Serviceable In-line, Plus Standard Feature Drain

All valve components are fully replaceable for service or repair. Top entry allows easy access to components without removal from system. The convenient O-ring sealed Drain Plug allows quick-flush of any accumulated debris from bottom of valve.

C_v Values

Valve Size	C _v
3/4	18
1	24
1-1/2	70
2	95
2-1/2	300
3	300
4	480
6	1100
8	1900

Viton® is a registered trademark of Dupont Dow Elastomers.

Sample Engineering Specification

All thermoplastic check valves shall be flanged Swing Check type constructed from PVC Type I, ASTM D 1784 Cell Classification 12454 or CPVC Type IV, ASTM D1784 Cell Classification 23447, or Polypropylene, ASTM D 4101. All O-rings shall be EPDM or genuine Viton®. All valves components shall be replaceable. All valves shall have top-entry access with O-ring sealed drain plug for in-line servicing. All valves shall have optional external Arrow Position Indicator or optional external Counter Balance. All 3/4" - 4" valves shall be pressure rated to 150 psi, all 6" valves to 100 psi, and all 8" valves to 70 psi for water at 73°F, as manufactured by Spears® Manufacturing Company.



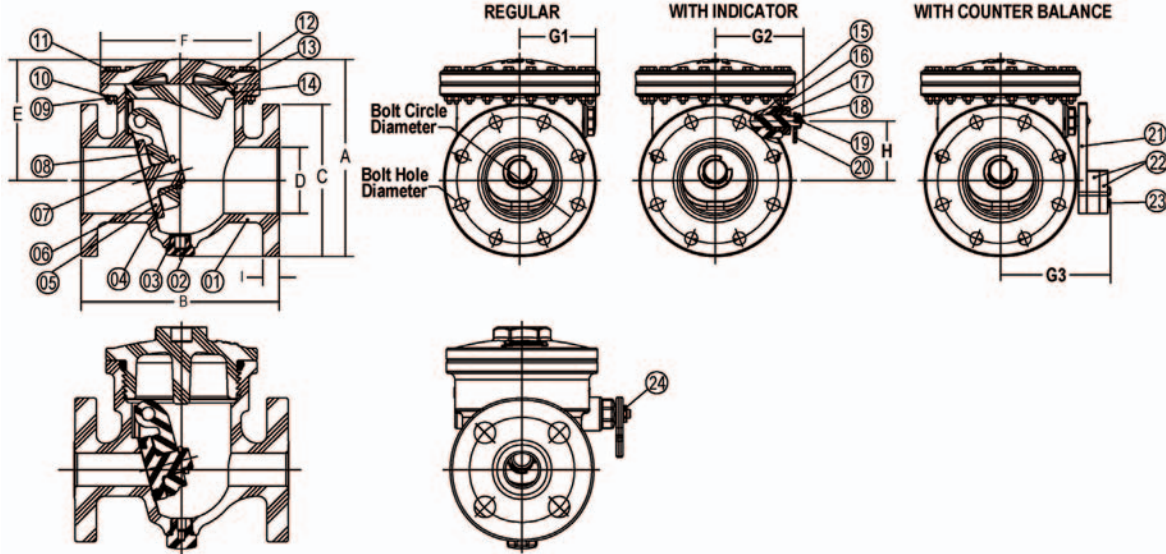

FOR SIZES 3/4" AND 1" ONLY

No.	Component	Qty.	Material
01	Body	1	PVC 1/CPVC/PP
02	Plug	1/2'	PVC 1/CPVC/PP
03	Plug O-ring	1/2'	EPDM/VITON®
04	Disc O-ring A	1	EPDM/VITON®
05	Disc	1	PVC 1/CPVC/PP
06	Disc Ret. Clip	1	PP
07	Disc O-ring B	1	EPDM/VITON®
08	Swing Arm	1	PVC 1/CPVC/PP
09	Nut	12-30	SS316
10	Washer	24-60	SS316
11	Bolt	12-30	SS316
12	Bonnet	1	PVC 1/CPVC/PP

No.	Component	Qty.	Material
13	Seal Carrier	1	PVC 1/CPVC/PP
14	Body O-ring	1	EPDM/VITON®
15	Arm Pin	1	PVC 1/CPVC/PP
16	Arm Pin Seal	2	VITON®
17	Arm Pin Plug	1	PVC 1/CPVC/PP
18	Arm Pin Washer	1	SS316
19	Arm Pin Bolt	1	SS316
20	Indicator	1	PP
21	Counterbalance	1	PVC 1
22	Weight Block	1	PVC 1
23	Weight Block Bolt	2	SS316
24	Arm Pin Ret. Clip	1	PP

1: Use 2 pcs. for regular non-indicated valve

Nominal Size	A	B	C	D	E	F	G1	G2	G3	H	I
3/4	5-5/16	5-1/2	3-7/8	3/4	3-3/4	3-3/4	2-9/16	3	TBA	1-7/16	1/2
1	6-5/8	6-5/16	4-1/4	31/32	4-1/2	4-1/2	2-25/32	3-7/32	TBA	1-21/32	5/8
1-1/2	7-3/8	7-3/32	5	1-19/32	4-9/16	5-3/4	3-3/16	3-25/32	TBA	1-27/32	23/32
2	8-1/2	7-7/8	6	2	5-1/4	7	3-9/16	4-1/8	TBA	2-29/32	13/16
2-1/2	10-3/4	10-1/4	7-1/2	3-1/8	6-3/4	8-5/8	4-1/4	5	6-9/32	3-1/16	7/8
3	10-3/4	10-1/4	7-1/2	3-1/8	6-3/4	8-5/8	4-1/4	5	6-9/32	3-1/16	7/8
4	11-3/4	11-13/16	9	3-29/32	7-1/4	9-1/2	4-1/2	5-1/4	6-17/32	3-17/32	31/32
6	15-5/8	15-3/4	11	5-7/8	9-1/2	13-7/16	6	6-3/4	8-1/32	5-1/32	1
8	19-1/8	19-23/32	13-1/2	7-7/8	11-5/8	16-5/16	7	7-3/4	9-1/32	6-1/2	1-5/32

TBA: To Be Announced

Nominal Size	Bolt Circle Diameter	Bolt Hole Diameter	Number of Bolt Holes
3/4	2-3/4	5/8	4
1	3-1/8	5/8	4
1-1/2	3-7/8	5/8	4
2	4-3/4	3/4	4
2-1/2	5-1/2	3/4	4
3	6	3/4	4
4	7-1/2	3/4	8
6	9-1/2	7/8	8
8	11-3/4	7/8	8