

PVC & CPVC CLAMP-ON SADDLES

COS-2-0902

Simple Two-Piece Design Engineered for Reliability



Excellent Metal-to-Plastic System Transition

Easily installs on metal pipe as a transition to plastic system.

PVC & CPVC Tee or Cross Configurations

Available in PVC White, PVC Gray or CPVC in 2" - 12" IPS pipe saddle with socket outlets in sizes 1/2" - 6" and Stainless Steel Reinforced (SR) threaded outlets in sizes 1/2" - 6", single Tee or double Cross configurations.

Patented SR Design Female Threads

Patented Stainless Steel Reinforced (SR) design on female thread outlets for superior strength.

O-ring Options

Choice of high grade Buna-N or EPDM O-rings for schedule 40 and EPDM or Viton® O-rings for Schedule 80, for application specific selection for optimum chemical resistance.

Multi-Bolt Design, Choice of Hardware

Positive attachment eliminates splitting problems associated with plastic wedge fasteners and outperforms 2-Bolt clamp saddle designs. Choose zinc plated or stainless steel nut, bolt and washer hardware.

Excellent Pressure Capabilities

Maximum internal pressure rating of 235 psi through 4", 200 psi for 6", and 150 psi for 8" - 12" at 73°F.

Spears PVC & CPVC Clamp-On Saddles allow quick, easy and reliable addition of branch lines to existing piping system lines. These versatile saddle units can be used in either temporary or permanent installations on all types of pipe with IPS (Iron Pipe size) outside diameter, such as PVC, CPVC, Polyethylene, Polypropylene and Steel.

O-ring seal provides positive, trouble-free sealing to pipe.

Special pilot engages with hole in pipe to prevent saddle dislocation.

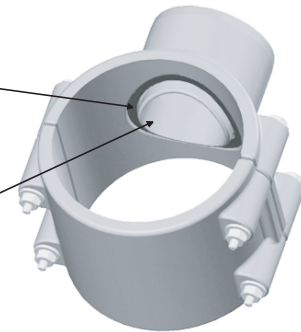

Sample Engineering Specification

All thermoplastic valves shall be clamp-on type with O-ring seal constructed from PVC Type I cell classification 12454 or CPVC Type IV cell classification 23447. All O-rings shall be Buna-N, EPDM or Viton®. All saddles shall be piloted at O-ring area for positive positioning in pipe. All bolt clamping hardware shall be zinc plated steel or stainless steel. All threaded saddle outlets shall be Steel Reinforced (SR) design. Saddles shall be pressure rated at 235 psi for use on pipe sizes through 4" nominal IPS diameters, 200 psi for use on 6" pipe, and 150 psi for use on 8" - 12" pipe, maximum internal pressure for water at 73°F, as manufactured by Spears Manufacturing Company.

Viton® is a registered trademark of DuPont Dow Elastomers.



Quality Systems Certificate No. 293
Corporate Facilities, Sylmar, CA
Assessed to ISO 9001

Simple Installation

1. Using a standard industrial grade hole-saw, cut specified hole in desired position on pipe according to recommended hole saw size engraved on the saddle. *Note: Care must be taken to deburr hole and remove all residue from hole area to assure tight fit and avoid leakage.*
2. Fully seat O-ring in groove on underside of saddle outlet component. Position over hole and fully seat saddle onto pipe. *Note: Saddle outlets are piloted. Be sure pilot lip fully engages with hole in pipe.*
3. Place strap component opposite outlet and secure with bolts (4), nuts (4) and washers (8). *Important: Washers MUST be placed under each bolt head (1) and under each nut (1) to avoid damage to saddle.*
4. Tighten bolts to specified torque:

Saddle x Outlet Size	Recommended Hole Size	Recommended Bolt Torque ft/lbs
2 x 1/2	3/4	8
2 x 3/4	7/8	8
2 x 1	1-1/8	8
2 x 1-1/4	1-1/2	8
2 x 1-1/2	1-1/2	8
2-1/2 x 1-1/2	1-3/4	8
3 x 1/2 ¹	7/8	8
3 x 3/4	7/8	8
3 x 1	1-1/8	8
3 x 1-1/4 ¹	2-1/4	8
3 x 1-1/2 ¹	2-1/4	8
3 x 2	2-1/4	8
4 x 1/2 ¹	1-1/8	8
4 x 3/4 ¹	1-1/8	8
4x1	1-1/8	8
4 x 1-1/4 ¹	1-3/4	8
4 x 1-1/2	1-3/4	8
4 x 2	2-1/4	8
4 x 2-1/2 ¹	3	8
4 x 3	3	8

¹= Outlet-Sized with Bushing

Saddle x Outlet Size	Recommended Hole Size	Recommended Bolt Torque ft/lbs
6 x 1/2 ¹	1-1/8	10
6 x 3/4 ¹	1-1/8	10
6 x 1	1-1/8	10
6 x 1-1/4 ¹	2-1/4	10
6 x 1-1/2 ¹	2-1/4	10
6 x 2	2-1/4	10
6 x 2-1/2 ¹	3	10
6 x 3	3	10
6 x 4	4	10
8 x 1/2 ¹	4	10
8 x 3/4 ¹	4	10
8 x 1 ¹	4	10
8 x 1-1/4 ¹	4	10
8 x 1-1/2 ¹	4	10
8 x 2 ¹	4	10
8 x 2-1/2 ¹	4	10
8 x 3 ¹	4	10
8 x 4	4	10
8 x 6	6	10
10 x 4	4	10
10 x 6	6	10
12 x 4	4	10
12 x 6	6	10